

WEDGE MOUNTS, Series DTSP Bolt Thru with Spherical Positioners

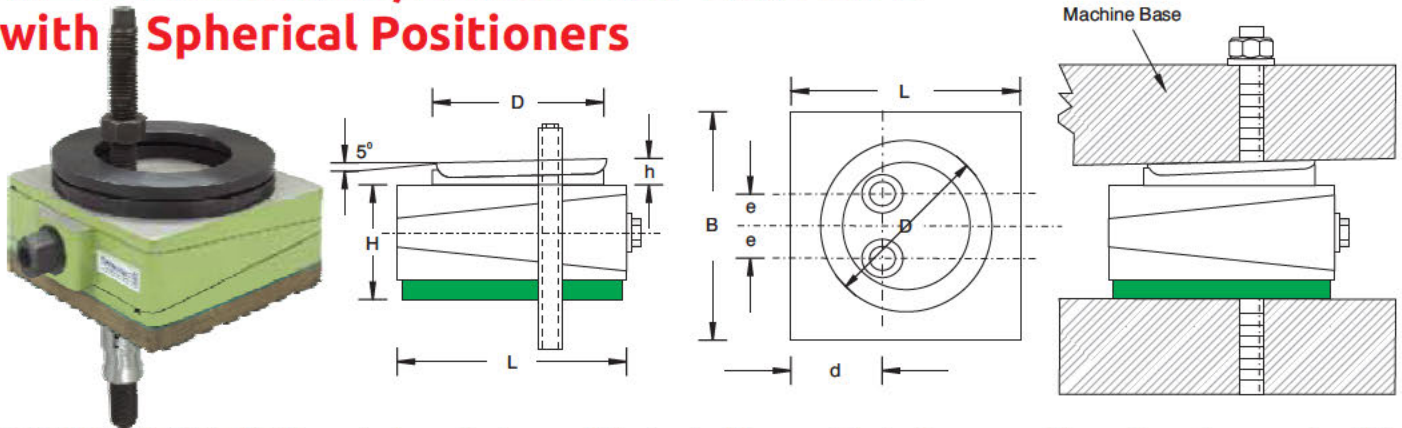

SPHERICAL POSITIONERS are designed to transmit the load of the machine to the ground through wedge mounts at 90 degree despite the angle difference between machine base and foundation. The pressure on the insulation plates remain even. Thus, better alignment is possible. Variations are available for free standing and bolt on machine bases either with or without insulation damping. Dynemech is open to the idea of developing **customer specific requirements**.

Model	Load Kg/pc	Length (L) mm	Width (B) (mm)	Height (H) at mean position (mm)	d (mm)	e (mm)	bore Ø (mm)	h (mm)	D (mm)	Adjst. range with Anchnrut both (mm)
DTSP1-i	1800	115	115	69	50	24	22	19	110	8
DTSP2-i	2900	150	150	75	60	23	22	20	150	10
DTSP3-i	5200	200	200	75	75	27	28	22	200	12
DTSP4-i	6500	200	250	95	95	27	28	22	200	18
DTSP5-i	10000	250	320	100	125	55	28	28	250	18
DTSP6-i	15000	300	400	100	148	50	30	32	300	20
DTSP1-s2	950	115	115	69	50	24	22	19	110	8
DTSP2-s2	1600	150	150	75	60	23	22	20	150	10
DTSP3-s2	2800	200	200	75	75	27	28	22	200	12
DTSP4-s2	3500	200	250	95	95	27	28	22	200	18
DTSP5-s2	5500	250	320	100	125	55	28	28	250	18
DTSP6-s2	8500	300	400	100	148	50	30	32	300	20

COMPAC MACHINERY MOUNTS, Series DH

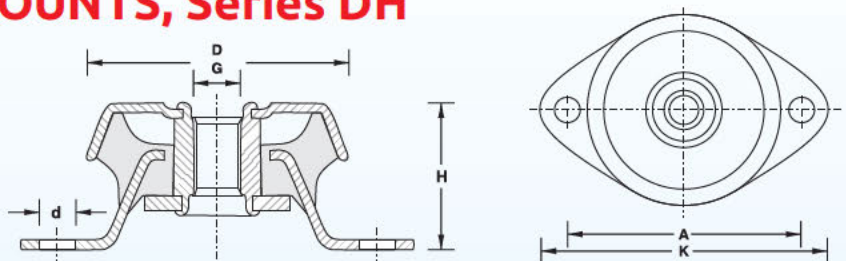

Dynemech Compac Machinery Mounts uses rubber in compression and shear. They provide tight tolerances on stiffness rate for accurate vibration calculations. Load range is from 40 to 130 Kgs per piece. The strong base metal withstands high shock loads without deformation. Fitted as standard with a shock proof device (up to 4.5g) with resilient stop, it is ideal for mobile or marine use. Domed shape cover to protect against oil contamination. Light weight and compact. ideal for **Diesel engines, Compressors Cooling Towers, Pumps, Industrial generators, Marine generators, ID, FD Fans** etc.

Model	D	A	H	K	d	G	Weight (Kg.)	Load Capacity (Kg.)
DH 1	64	76	35	93	9.5	M12/M10	0.22	130
DH 2	64	76	35	93	9.5	M12/M10	0.22	105
DH 3	64	76	35	93	9.5	M12/M10	0.22	70